

RECTIFIER

PSR380

(110 & 220V VERSION)

USER MANUAL



Notes to this manual

ATTENTION! Read this manual very carefully before installing and commissioning the specified module.

This manual is a part of the delivered module. Familiarity with the contents of this manual is required for installing and operating the specified module.

The rules for prevention of accidents for the specific country and the general safety rules in accordance with IEC 364 must be observed.

The function description in this manual corresponds to the date of publishing.

Technical changes and changes in form and content can be made at any time by the manufacturer without notice.

There are no obligations to update the manual continually.

The module is manufactured in accordance with applicable DIN and VDE standards such as VDE 0106 (part 100) and VDE 0100 (part 410). The CE marking on the module confirms compliance with EU standards 2006-95-EG (low voltage) and 89/339 EWG (electromagnetic compatibility) if the installation and operation instructions are followed.

Supplier:

	ELTEK VALERE INDUSTRIAL GmbH Schillerstraße 16 D-32052 Herford
	+ 49 (0) 5221 1708-210
FAX	+ 49 (0) 5221 1708-222
Email	Info.industrial@eltekvalere.com
Internet	http://www.eltekvalere-industrial.com

© Copyright ELTEK VALERE INDUSTRIAL 2007. All rights reserved.

The current revision status of this user manual is the following:

Revision: 1.0

Date: 2009-03-10

Revision	Description of change	Writer	Date
00	Revision of the former edition "UM_PSR380_2006_E_R03" (layout change, limited to 110/220V version)	RTH	2007-11-08
01	Section "Commissioning" reworked, section "CAN-Bus addressing" inserted, minor text modifications	RTH	2008-04-24
1.0	Index of figures inserted, minor text modifications, new revision status numbering (X.X) introduced.	RTH	2009-03-10

Table of contents

1. SAFETY INSTRUCTIONS AND WASTE DISPOSAL RULES	5
2. GENERAL INFORMATION.....	6
3. TYPE RANGE/EQUIPMENT	6
3.1 MAIN DATA	6
3.2 AVAILABLE OPTIONS AND ASSEMBLY EQUIPMENT	6
3.3 FRONT VIEW/OPERATION ELEMENTS.....	7
3.3.1 LED Display	7
3.3.2 Digital Displays	7
3.4 ELECTRICAL CONNECTORS.....	8
3.5 COOLING AND AIR FLOW DIRECTION	9
3.6 COMMUNICATION INTERFACE	9
4. HANDLING.....	10
4.1 STORAGE.....	10
4.2 COMMISSIONING.....	10
4.2.1 CAN-Bus Addressing.....	10
4.3 CHARGE CHARACTERISTIC CURVE/OUTPUT POWER DIAGRAM	11
4.3.1 Output current at different output voltage values	11
4.4 LED INDICATIONS.....	12
4.5 MONITORING.....	12
4.6 FACTORY-PRESET DEFAULT AND THRESHOLD VALUES	13
4.6.1 Adjustment procedure of the default and threshold values	13
5. EXTERNAL FUNCTIONS.....	14
6. MAINTENANCE	14
7. TROUBLE SHOOTING	14
8. TECHNICAL SPECIFICATIONS.....	15
8.1 DIMENSIONAL DRAWINGS	17
9. NOTES	18

Index of figures

Figure 1) Front view.....	7
Figure 2) Electrical connectors (110 & 220V version).....	8
Figure 3) Module airflow.....	9
Figure 4) Output power diagram (PSR380/110V)	11
Figure 5) Module dimensions	17

1. Safety Instructions and Waste Disposal Rules



Warning!

Because several components of operating electrical modules are charged by dangerous voltage, the improper handling of electrical modules may be the cause of accidents involving electrocution, injury, or material damages.

- Operation and maintenance of electrical modules must be performed by qualified skilled personnel such as electricians in accordance with EN 50110-1 or IEC 60950.
 - Install the module only in areas with limited access to unskilled personnel.
 - Before starting work, the electrical module must be disconnected from mains. Make sure that the module is earthed.
 - Do not touch connector pins as they can be charged with dangerous voltage up to 30 seconds after disconnection.
 - Only spare parts approved by the manufacturer must be used.
-

All electric modules must be disposed of separate from domestic waste at collecting points that have been set up by the government or municipal authority.

“Separate collection is the precondition to ensure specific treatment and recycling of WEEE and is necessary to achieve the chosen level of protection of human health and the environment in the Community.”

The above statement from EU directive 2002/96/EC applies to all electric modules installed within EU countries.

In countries outside the EU, different rules may apply regarding waste disposal of electric modules.

For more information about waste disposal of your discarded equipment, contact your ELTEK VALERE INDUSTRIAL partner.

2. General Information

The rectifier PSR380 rectifies sinusoidal three-phase AC input voltage to DC output voltage. The PSR380 has rear side connectors and is designed to be mounted in an assembly kit (19" sub rack) according to section 3.2. Due to the state-of-the-art circuit design the unit has low losses and therefore very compact dimensions, low weight and a very high power density. The PSR380 can be used in all DC applications with or without battery.

The nominal output power per unit is 8000 W. Several units can be switched in parallel to increase the system output power or to build redundant power supply systems (n + 1-principle).

3. Type Range/Equipment

Type Designation	Article Code	Nominal Output Voltage	Nominal Output Current
PSR380/110-74	101-080-271.00	108V _{DC}	74A _{DC}
PSR380/220-37	101-080-281.00	216V _{DC}	37A _{DC}

3.1 Main Data

Nominal Input Voltage:	3 x 400V _{AC}
Nominal Input Current:	13.1A _{AC} per phase
Input Frequency:	47- 63Hz
Nominal Output Power:	8000W

For more specific data, see section 8.

3.2 Available Options and Assembly Equipment

Designation	Material Code
Assembly kit (19" sub rack 3U incl. backplane) for one rectifier PSR380	102-380-101.HV01

3.3 Front View/Operation Elements

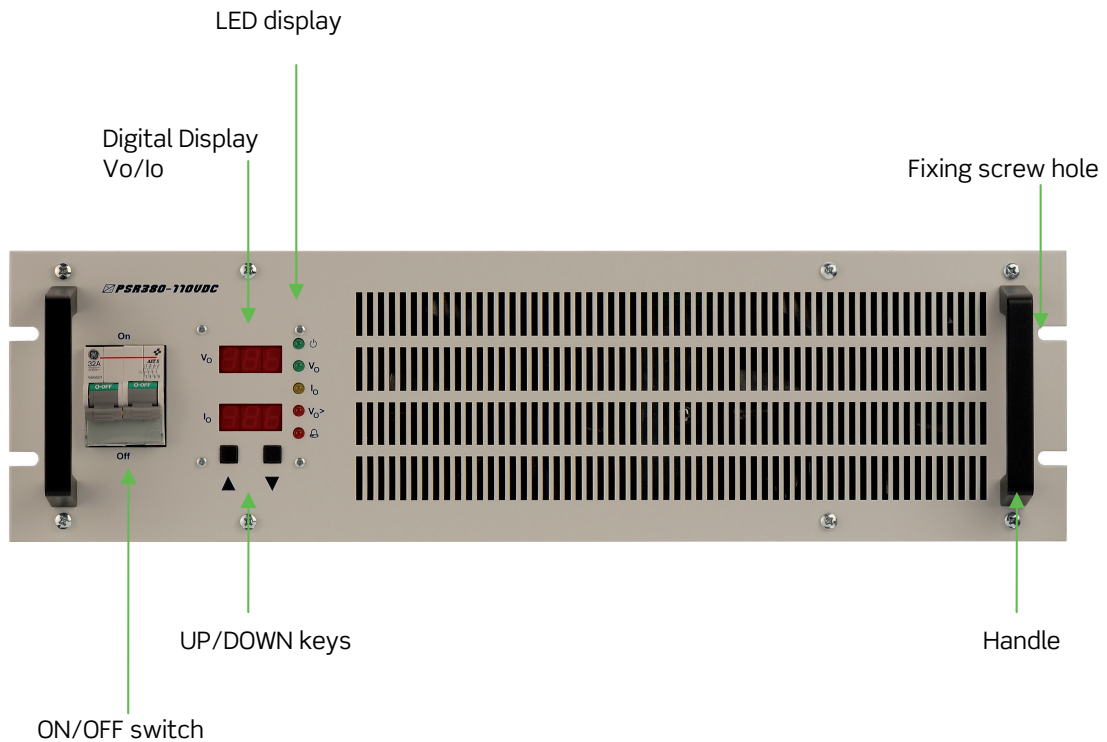

Figure 1) Front view

3.3.1 LED Display

As shown above the unit is equipped with the following five LED indications:

- MAINS,
- OUTPUT OK,
- Iout max
- Vout>,
- ALARM

3.3.2 Digital Displays

In the initial state (operating mode), the upper display indicates the output voltage, the lower display indicates the output current. At the setting mode (see section 4.6.1) the parameters to be set are shown at the displays.

For more information about the displays and operation elements, see the following sections.

3.4 Electrical Connectors

The PSR380 is designed to be mounted in an assembly kit (19" sub rack) with backplane. Figure 2) shows the terminal area (AC input, DC output and signals) of the backplane.

Figure 2) Electrical connectors (110 & 220V version)
shown from the rear side of the backplane

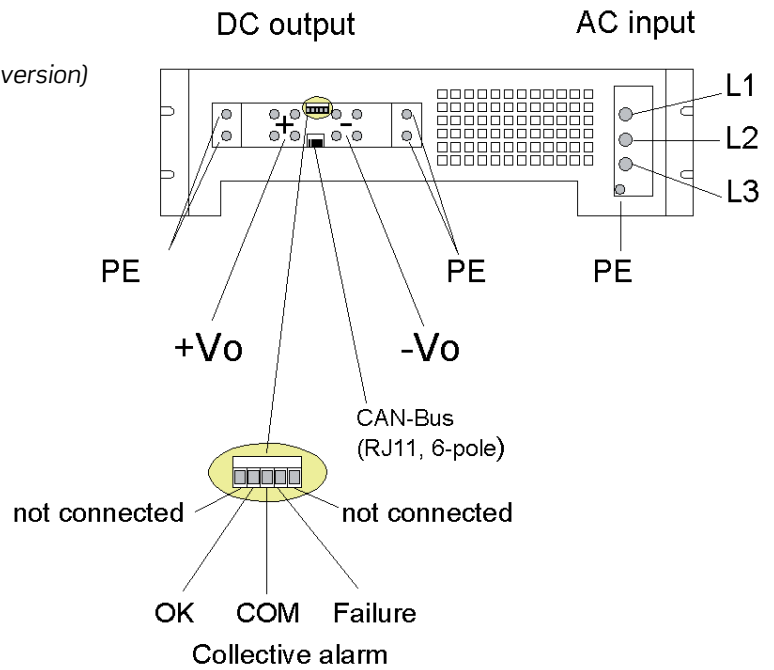

3.5 Cooling and Air Flow Direction

The unit is cooled with two internal fans. The airflow is from the front to rear side. The fans are monitored and speed controlled dependent on module temperature. To provide sufficient air flow, a minimum space (see item "A" in figure 3) of 50 mm is required between the air outlet of the unit and the rear cabinet wall as well as an unobstructed supply of air to the front of the module.

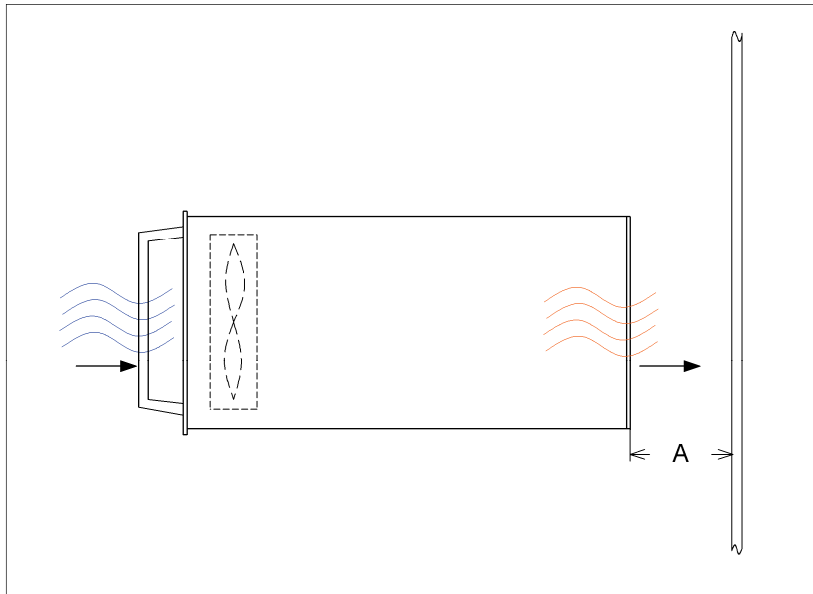

Figure 3) Module airflow

3.6 Communication Interface

The PSR380 rectifier is equipped with a serial data interface in accordance with the Controller Area Network (CAN) specification. The CAN-Bus connection is integrated in the rear side connector of the module and is available as an RJ11 (6-pole) connector at the backplane of the assembly kit.

Several modules in a system or parallel connection can be controlled and monitored through the CAN-Bus by a central UPC3 DC controller unit.

The following parameters of a specific rectifier unit can be controlled or monitored:

- Output voltage
- Output current
- Device temperature
- Device status

Furthermore, the rectifier unit receives all threshold values through the CAN-Bus from the DC controller unit.

4. Handling

4.1 Storage

The modules must be stored in a dry, dust free environment with a storage temperature in accordance with the specified technical data (see section 8.).

4.2 Commissioning

Note: Before commissioning the module, make sure that the input voltage corresponds to the input voltage range of the unit as specified on the type plate and that the output voltage of paralleled units matches.

An assembly kit (19" sub rack, see section 3.2) is to be used to integrate the module in a power supply cabinet.

1. Carefully unpack the unit
2. Put the unit into the slot of the sub rack.
3. Carefully slide in the unit until the module connectors touched the backplane connectors.
4. Increase the force until the unit fits in completely. Avoid using too much force. If the unit does not fit in, begin again at step 2.
5. Secure the module using four screws (M4x12).

Note: The PSR380 (110 & 220V version) is not serially equipped with an internal decoupling on the output. An external decoupling diode is required for hot plug-in functionality (that enables the operator to **add** modules even under operating conditions).

Note: But if the module is to be **removed** it previously must be **switched off** by the input fuse!

Caution: After switching off the module, the internal capacitors are still fully charged. Do not touch connector pins as they can still be charged with dangerous voltage after disconnection.

The device must be protected by an external MCB (3 phases).

After the module is switched on via the switch (On/Off) at the front plate, it starts with current limitation mode (max. inrush current= I_{nom}).

4.2.1 CAN-Bus Addressing

If several modules operate in parallel connection and in combination with a central DC controller unit, the modules are controlled and monitored through the CAN-Bus by the controller unit. An individual address must be allocated for each module for a clear identification through the controller unit. The addresses must be set before starting the system.

The CAN-Bus addressing of the PSR380 modules is described in the following:

1. Press both front keys until the display changes.
2. Key in code "005", enter with pressing both keys.
3. Now, the address can be changed by pressing the UP or DOWN key.
4. Store the new address with pressing both keys.

4.3 Charge Characteristic Curve/Output Power Diagram

The charge characteristic curve of the PSR380 is a power limited IV-characteristic curve according to DIN 41772/DIN 41773.

For devices in parallel operation mode a current balancing of approximately $\pm 10\%$ is attained due to a sloping output voltage line (-1% at 100% I_{max}). The device is continuous short circuit proof due to constant current control.

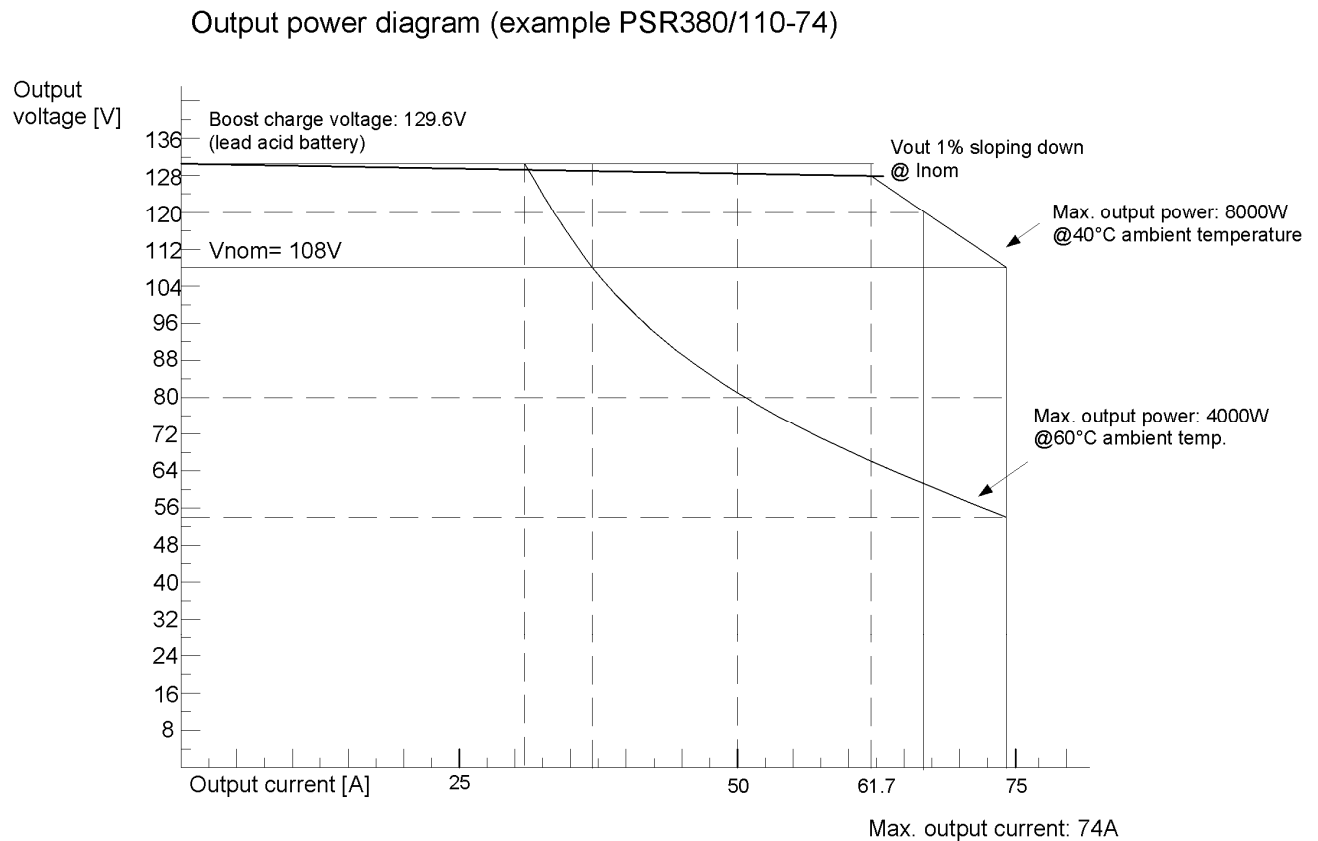

Figure 4) Output power diagram (PSR380/110V)

4.3.1 Output current at different output voltage values

Example: PSR380/110V

The nominal output power (P_{onom}) of the PSR380 is **8000W**.

The maximum output current (74A) is available at \leq nominal output voltage (108.0V).

At other output voltage values such as **float** (or **boost**) charge voltage, the output current is to be calculated by the following formula: $I_o = P_{onom} : V_o$





Examples:

The **float charge voltage** for lead acid batteries (54 cells)= 122.6V; $I_o = 8000W : 122.6V = \mathbf{65.2A}$

The **boost charge voltage** for lead acid batteries (54 cells)= 129.6V; $I_o = 8000W : 129.6V = \mathbf{61.7A}$

4.4 LED Indications

The following functions are indicated with front side LED's:

LED	Colour	Function
	green	Mains input voltage ok (criterion: $340V_{AC} \leq V_n \leq 460V_{AC}$)
	green	Vout ok 1. criterion without constant current control: Vout \geq 85% of adjusted value* 2. with constant current control: Vout \geq 85% of adjusted value*
	yellow	Constant current mode "Iomax"
	red	Vout > (criterion: Vout \geq than adjusted operating threshold)*
	red	Collective fault**: Vin incorrect, Vout incorrect, Vout>; device over temperature (LED blinking)

*For factory-preset output voltage threshold values, see section 4.6

**The device is equipped with an isolated signalling contact (change-over contact).

The maximum load is 60V_{DC}/500 mA. The contact is time-delayed and reacts after approximately 10 seconds.

4.5 Monitoring

Monitored values	Criteria	Function
AC input voltage	Mains input voltage $340 \leq V_n \leq 460V$	The module automatically switches off.
DC output voltage	Output voltage higher than the adjusted operating threshold*	The module automatically switches off (self locking). The unit must be manually restarted.
Device temperature	Cooling plate temperature $\geq 90^\circ C$	The module automatically switches off. It automatically switches on when the cooling plate cooles down to $\leq 80^\circ C$.
Short circuit	The module automatically detects short circuit operation by the output voltage value. (criterion: Vout \leq 83% of Vnom)	The unit automatically switches off. After 30 sec. the unit automatically tries to restart for 3 times. If this fails the module switches off and must be manually restarted.

*For factory-preset output voltage threshold values, see section 4.6

4.6 Factory-preset default and threshold values

The following default values (factory-preset) are stored in the PSR380. But the values can be changed by the user according to his requirements (see section 4.6.1).

Default values	110V version	220V version
Vo (V _{DC})	122.6	245.2
Vo> (V _{DC})	135.0	270.0
Iconst (A _{DC})	74.0	37.0

If an UPC3 DC controller unit is controlling the power supply unit through the CAN-Bus, the charge voltage is completely controlled by the UPC based on its configuration values and momentary charge state (for example temperature compensation, boost charge, or battery test).

When the CAN-Bus connection is inactive for more than 5 seconds, the PSR380 automatically switches back to the internally stored default values. In this case it is ensured that the battery will be charged in the float charge mode.

4.6.1 Adjustment procedure of the default and threshold values

The user is able to adjust the default and threshold values very easy via the front keys.

The selection of the changeable values is to be done via the front keys (▲ and ▼).

In the initial state the top display indicates the output voltage (V_{out}), the bottom display indicates the output current I_{out} (operation mode).

For any adjustment please follow these instructions:

- press both keys (▲ and ▼) together for a short time; the rectifier changes to the **adjustment mode**
- press the key UP (▲) or DOWN (▼) to change the adjustment parameter (see the table “Adjustable parameters in the adjustment mode”)
- press both keys (▲ and ▼) together for a short time; the rectifier changes to the **value change mode**
- press the key UP (▲) or DOWN (▼) to change the adjustment value (if you hold down the key the value changes quicker)
- press both keys (▲ and ▼) together for a short time; the rectifier changes back to the **adjustment mode** (due to this the changed value will be saved)
- press both keys (▲ and ▼) for approx. 3 sec. to change back to the **operation mode**

You can leave the adjustment mode at any time via pressing both keys together (▲ and ▼) for approx. 3 seconds.

Table: Adjustable parameters at the adjustment mode:

Display	Parameter	110V version		220V version	
		Factory-preset values	Setting range	Factory-preset values	Setting range
Vo (V)	Charge voltage	122.6	91.8-135.0	245.2	184.0-270.0
I _{max} (A)	Max. output current	74.0	37.0-74.0	37.0	18.5-37.0
Vo< (V)	Output under voltage	91.8	86.4-108.0	184.0	173.0-216.0
Vo> (V)	Output over voltage	135.0	119.0-135.0	270.0	238-270.0

The operating thresholds of the output voltage monitoring automatically follow the adjusted desired value of the output voltage. The operating thresholds of the mains voltage and temperature monitoring are unchangeably factory-preset.

5. External Functions

If the rectifier works in combination with a DC controller unit UPC3 the following external functions can be used:

- Compensation of the output voltage
 - Temperature compensation of the charge voltage
 - Discharge test
 - Boost charge mode
- For more information about the external functions please read the UPC3 user manual.

6. Maintenance

In general, the rectifier is maintenance-free.
 A yearly inspection with following checks is recommended:

- Correct fan operation
- Mechanical inspection
- Removal of dust and dirt, especially on radiator surfaces

Attention! Dust combined with dew or water may influence or destroy the internal electronic circuits.

Dust inside the unit can be blown out with dry compressed air.
 The intervals between the checks depend on ambient conditions of the installed module.

7. Trouble Shooting

Symptom	Possible reason	Corrective action
No output voltage	<ul style="list-style-type: none"> • Is the mains input voltage present? • Mains switched in "ON" position? • PSR380 module plugged in securely? • Incorrect polarity or short circuit at the output? • Connected in parallel: incorrect polarity at external decoupling diodes? • LED Vo> on? 	Check Check Check Check Check 1.) Switch the unit off and on 2.) Check the settings for Vo> (see section 4.6)
Deviation of the output voltage	<ul style="list-style-type: none"> • Is the unit operating in current limiting mode due to overload? • Is the output voltage setting Vout at the DC controller incorrect? • If an external sensor lead for the output voltage is used: Is the connection faultless? 	Reduce the load Adjust the output voltage to nominal values (see section 4.6) Check

If the unit still does not work even though all checks are done, please contact your sales agent or the ELTEK VALERE INDUSTRIAL service department.

8. Technical Specifications

Type designation	PSR380/110-74	PSR380/220-37
Article code	101-080-271.00	101-080-281.00
AC input:		
Nominal input voltage	3 x 400V _{AC} ±20%	←
Nominal input current	13.1A _{AC} per phase	←
Input frequency range	47- 63Hz	←
Total harmonic distortion	<12%	←
Efficiency	≥88%	←
Internal input fusing	There is no internal input fuse; an external fuse is required (16A gl)	
DC output:		
Nominal output voltage	108V _{DC}	216V _{DC}
Max. output current (I _{omax})	74A _{DC} (@ 108V); Setting range 37-74A	37A _{DC} (@ 216V); Setting range 18.5-37A
Nominal output power	8000W	←
Charge characteristic line	IV characteristic line according to DIN41772/DIN41773; power limited	
Output voltage threshold Vo> (factory setting)	135V _{DC} ; Setting range 119-135V	270V _{DC} ; Setting range 238-270V
Adjustable output voltage range	91.8 – 135V _{DC} (1.7 - 2.5V/cell; lead acid battery)	184 – 270V _{DC} (1.7 - 2.5V/cell; lead acid battery)
Default value charging voltage	122.6V _{DC} (2.27V/cell; lead acid battery)	245.2V _{DC} (2.27V/cell; lead acid battery)
Voltage ripple	≤100mV _{pp}	≤200mV _{pp}
Dynamic accuracy of the charge voltage	<3% V _{nom} at load changes between 10%-90%-10% I _{omax} ; correction time ≤1.5ms	
Short circuit protection	sustained short circuit proof; 1x I _{nom}	
Parallel operation	Yes (max. 48 units with DC controller unit UPC3); current balancing ≤10% I _{omax} ; sloping output voltage line (-1% at 100% I _{omax})	
Internal decoupling at the output	no; external decoupling diode required (hot plug-in functionality)	
Internal output fuse	no, external fuse required	←

Type designation	PSR380/110-74	PSR380/220-37
Standard Features:		
LED signalling	Operation (green), Vo OK (green), Iomax (yellow); Vo > (red), collective fault (red)	
Main processor	16Bit Fujitsu	←
Isolated signalling contact	"Collective fault"; isolated relay contact COM/NC/NO; maximum load: 60V _{DC} /500mA	
Communications interface	CAN-Bus, proprietary protocol	
Ambient conditions:		
Ambient temperature	Operation: -20°C up to +55°C; Storage: -40°C up to +85°C	
Climate conditions	according to IEC 721-3-3 class 3K3/3Z1/3B1/3C2/3S2/3M2	
Max. installation altitude	≤ 1500m	
Noise emission	< 50dBA	←
Mechanical construction:		
Type of construction	19", 3U	←
Cooling	Fan cooling (temperature-regulated, monitored)	
Electrical connections	AC input, DC output and signalization: DIN41612-M-connector	
Dimensions (W/H/D)	483/133/420mm	←
Weight	approx. 28kg	←
Type of enclosure	IP20 (front panel)	
Colour (front panel)	RAL 7035; blackprint	
Compliances:		
CE conformity	yes	←
Compliance to safety standards	EN60950-1; VDE0100 T410; VDE0110; EN50178; EN60146	
Compliance to EMC standards	EN55011/22 class "B"; EN61000-4 T2-5	

8.1 Dimensional Drawings

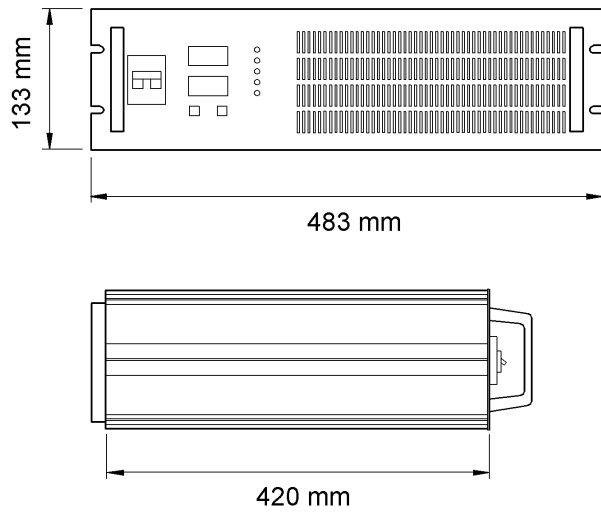

Figure 5) Module dimensions



Supplier:

	ELTEK VALERE INDUSTRIAL GmbH Schillerstraße 16 D-32052 Herford
	+ 49 (0) 5221 1708-210
FAX	+ 49 (0) 5221 1708-222
Email	Info.industrial@eltekvalere.com
Internet	http://www.eltekvalere-industrial.com