

RECTIFIER PSR06-W

USER MANUAL



Rectifier PSR06-W

User Manual
Page 2 (24)

ATTENTION! Read this manual very carefully before installing and commissioning the specified module. This manual is a part of the delivered module. Familiarity with the contents of this manual is required for installing and operating the specified module. The rules for prevention of accidents for the specific country and the general safety rules in accordance with IEC 364 must be observed.

The function description in this manual corresponds to the date of publishing. Technical changes and changes in form and content can be made at any time by the manufacturer without notice. There are no obligations to update the manual continually.

The module is manufactured in accordance with applicable DIN and VDE standards such as VDE 0106 (part 100) and VDE 0100 (part 410). The CE marking on the module confirms compliance with EU standards 2006-95-EG (low voltage) and 89/339 EWG (electromagnetic compatibility) if the installation and operation instructions are followed.

Supplier:

	Eltek Valere Deutschland GmbH Industrial Division Schillerstraße 16 D-32052 Herford
	+ 49 (0) 5221 1708-210
FAX	+ 49 (0) 5221 1708-222
Email	Info.industrial@eltekvalere.com
Internet	http://www.eltekvalere.com

© Copyright ELTEK VALERE DEUTSCHLAND GmbH 2009. All rights reserved.

Rectifier PSR06-W

User Manual
Page 3 (24)

The current revision status of this user manual is the following:

Revision: 1.1

Date: 2009-04-16

Revision	Description of change	Writer	Date
00	Reworked edition on base of the further manual "BHB-PSR06-W.D25-1000.HB101": Layout changed, several minor text corrections	RTH	2008-02-14
1.0	New revision status numbering (X.X) introduced, values for input voltage range changed (> >wide input range).	RTH	2009-04-08
1.1	Minor text modifications	RTH	2009-04-16

Table of Contents

SAFETY INSTRUCTIONS AND WASTE DISPOSAL RULES	5
1. GENERAL INFORMATION	6
2. TYPE RANGE.....	6
3. START UP PROCEDURE	7
4. OPERATION.....	7
5. FUNCTIONS.....	8
5.1 Circuit diagram.....	8
5.2 Electrical function description.....	9
5.2.1 Electrical insulation.....	9
5.2.2 Input.....	9
5.2.3 Output.....	10
5.2.4 Dynamic Regulation of Output Voltage.....	10
5.2.5 RFI Suppression.....	10
5.3 Monitoring.....	10
5.3.1 Mains Voltage Monitoring.....	10
5.3.2 Operation Monitoring.....	10
5.3.3 Output Voltage Low.....	11
5.3.4 Output Voltage High.....	11
5.3.5 Protection against Overheating.....	11
5.3.6 Signals.....	11
5.4 Output and threshold adjustment.....	12
6. EXTERNAL FUNCTIONS.....	13
6.1 Output voltage sensor leads.....	13
6.2 Temperature Compensation of the charging voltage.....	13
6.3 External Switch On/Off.....	13
6.4 Boost Charge Mode.....	13
7. OPERATION ELEMENTS AND CONNECTORS.....	14
7.1 Front View / Operation Elements.....	14
7.2 Indication Instruments.....	14
7.3 Connection Table of Input and Output Terminals.....	15
8. MAINTENANCE.....	16
9. FAULT FINDING INSTRUCTIONS.....	17
9.1 Output voltage failure.....	17
9.2 Output voltage deviation.....	17
10. TECHNICAL DATA.....	18
10.1 General Technical Data.....	18
10.2 Type Specific Data.....	20
11. DIMENSIONAL DRAWINGS/FRONT VIEW.....	21
12. NOTES.....	22

Safety Instructions and Waste Disposal Rules



Warning!

Because several components of operating electrical devices are charged by dangerous voltage, the improper handling of electrical devices may be the cause of accidents involving electrocution, injury, or material damages.

- Operation and maintenance of electrical devices must be performed by qualified skilled personnel such as electricians in accordance with EN 50110-1 or IEC 60950.
 - Install the module only in areas with limited access to unskilled personnel.
 - Before starting work, the electrical device must be disconnected from mains. Make sure that the module is earthed.
 - Do not touch connector pins as they can hold dangerous voltage up to 30 seconds after disconnection.
 - Only spare parts approved by the manufacturer must be used.
-

All electric devices must be disposed of separate from domestic waste at collecting points that have been set up by the government or municipal authority.

“Separate collection is the precondition to ensure specific treatment and recycling of WEEE and is necessary to achieve the chosen level of protection of human health and the environment in the Community.”

The above statement from EU directive 2002/96/EC applies to all electric devices installed within EU countries.

In countries outside the EU, different rules may apply regarding waste disposal of electric devices.

For more information about waste disposal of your discarded equipment, contact your ELTEK VALERE DEUTSCHLAND partner.

1. General Information

The primary switched mode rectifier type PSR06-W (named SMPS on the next pages) delivers an output power of approx. 600W. Typical applications are DC power supplies and uninterruptable power supply with battery. Rectifiers of type SMPS have good dynamic regulation properties concerning input voltage changes and load variations.

It works with an IV characteristic in accordance with DIN 41772 and it is a complete connectable module in a wall cabinet. The operation elements and measurement instruments are located on the front panel, the input/output connectors are located at the bottom of the module.

SNT modules also operates single side grounded or ungrounded at input and output.

2. Type Range

Type Designation PSR06/	Article code	Input voltage range (V _{AC})	Output-voltage (V _{DC})	Output-current (A)
24-20W	100-006-142.00	120-230 (-15/+10%)	24	20
48-10W	100-006-152.00	120-230 (-15/+10%)	48	10
60-8.2W	100-006-162.00	120-230 (-15/+10%)	60	8.2
110-4.5W	100-006-172.00	120-230 (-15/+10%)	108	4.5

Available options and accessories:

- 1) Temperature sensor lead LM 335 (sensor lead in M5 cable shoes with 2m wire); article code: **880-300-TMP.00**
- 2) Temperature sensor lead LM 335 (sensor lead in M5 cable shoes with 4m wire); article code: **880-300-TMP.01**

3. Start up procedure

Before connecting to the input voltage, it should be checked whether the voltage information on the rating plate corresponds to the available voltage and also that the polarity corresponds to the connection plan of the plug. The mains connection is done via terminals below the cabinet. The protective conductor should be generally connected (protection class 1, leakage current $\leq 3.5\text{mA}$).

The DC output contact has to be connected on terminal X1. The signalling contacts for monitoring, sense links and active current are to be connected on terminal X2/X3.

Important:

The rectifier has big capacitors at the output. If you connect a switched off module to a battery or other modules which operate in paralleling, there is a big capacitor charge current. This current may destroy the contacts on output connectors.

WARNING! After switching off, the capacitors hold its voltage for several times. Do not touch!

The rectifier operates with convection cooling. The ambient temperature has to be less than $+55^{\circ}\text{C}$. If there is a higher temperature, the life time of the modules will be decreased.
The losses per module are approx. 40 to 80W (depends on type).

4. Operation

All operation elements are located on the front panel of the module. The function of each element is explained on the following pages. See also the front panel drawing on section 7.1.

5. Functions

5.1 Circuit diagram

FIG. 1:
Block Diagram
PSR06-W

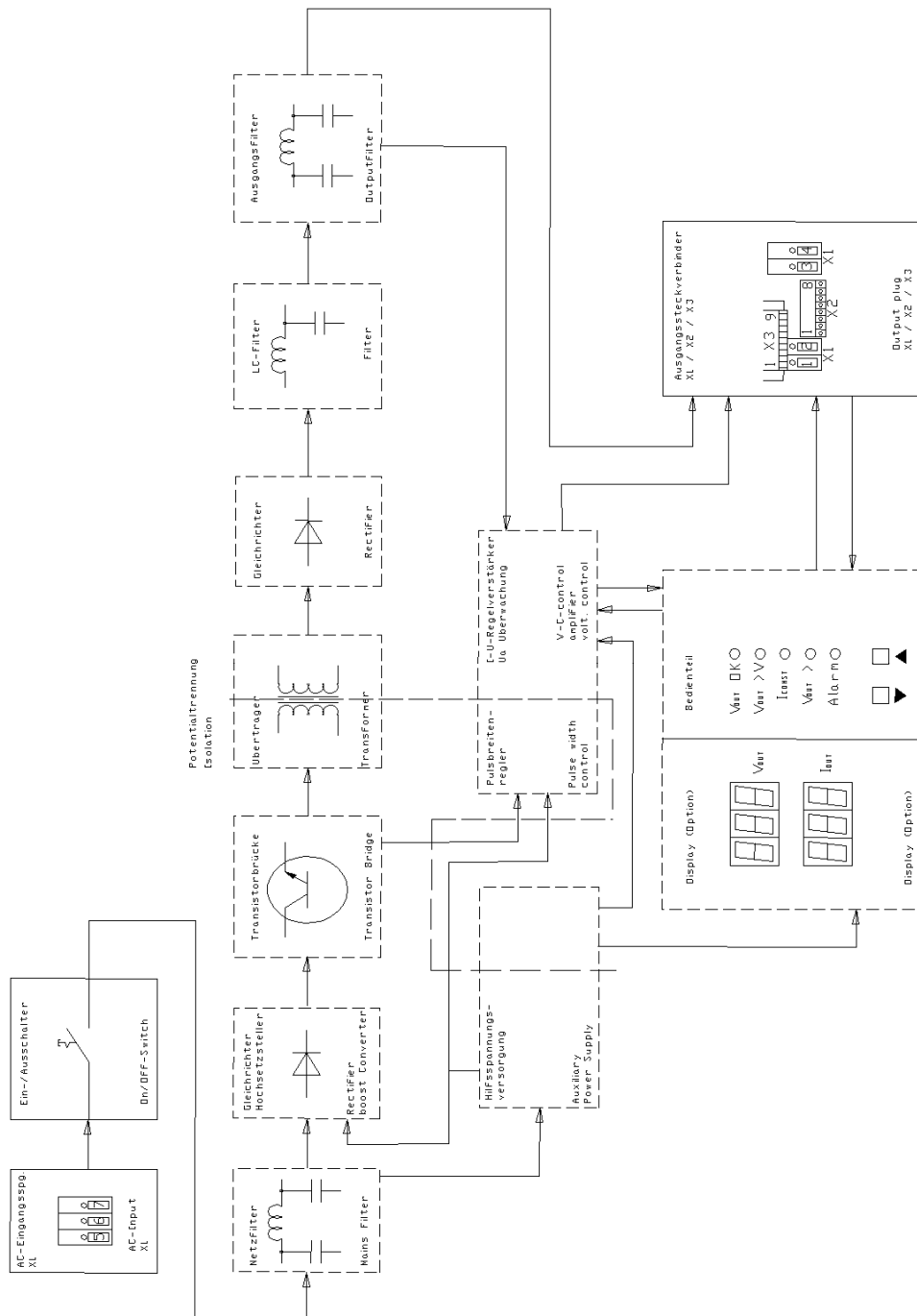

5.2 Electrical function description

Rectifiers of type PSR consist of the following main parts:

1. Input filter suppressing the feedback of high frequency interference produced by the unit into the mains as well as for the attenuation of the interference voltages and voltage transients superimposed on the mains.
2. Mains rectifier with switched step-up-converter (operation frequency 100kHz) to transform the input voltage in a pre-regulated DC voltage of approx. 380V and to control the waveform of input current (sinusoidal!). An additional function is the limitation of inrush current.
3. Transistor bridge to transform the 380Vdc in a pulse width modulated AC voltage with an frequency of 100KHz.
4. HF transformer for decoupling of primary and secondary part and to transport the power to secondary side.
5. Rectifier diodes to make a DC voltage from high frequency AC voltage.
6. LC-Filter to reduce the voltage ripple on rectifier output.
7. Output filter for RFI suppression and to reduce the noise level on DC line.
8. Internal power supply for supplying of primary and secondary control units with potential decoupling.
9. Regulation line with decoupling through opto couplers.
10. Adjustment panel for adjustment of output parameters, signals and measurement instruments.

5.2.1 Electrical insulation

Through the construction of the module (also module parts) and separate wiring of mains input and DC output the SMPS fulfils the following standards:

- devices with $U_0 \leq 60V_{DC}$ protection against shock current because of low voltage with safe electrical decoupling acc. to EN 60950 and VDE 0100.
- devices with $U_0 > 60V_{DC}$ safe electrical decoupling to $U_0 = 220V_{DC}$ acc. EN 60950 and VDE 0160.

5.2.2 Input

A one-pole mains switch is used to switch on and off the unit.

The unit is switched on by a run-up stage which limits the switch-on current to $< I_{nom}$

5.2.3 Output

The output line is an IV characteristic acc. to DIN 41772 /DIN 41773 with factory set decreased charge line (-1% at 100% I_{nom}); with factory set active current sharing as option.
The output is sustained short circuit proof (constant current controlling).

5.2.4 Dynamic Regulation of Output Voltage

At load jumps between 10 % and 90 % I_{nom} / 90 % and 10 % I_{nom} the dynamic voltage difference is max. ± 3 % and will be regulated within max. 1.5ms to static levels.

5.2.5 RFI Suppression

Modules of type PSR fulfil the standard VDE 0878 T1 and EN 55011/55022 class 'B'. The output ripple is (measured psophometric acc. to CCITT) < 1,2mV (24V), < 1.8mV (48V and 60V).

5.3 Monitoring

5.3.1 Mains Voltage Monitoring

The SMPS is designed for an operation in the specified range (see technical data sheet).
The unit is protected for input voltages up to 270V_{AC} by a varistor at the input-side.

5.3.2 Operation Monitoring

Functional monitoring; signalling with LED "Vout OK", criterion: output voltage ≥ 97 % of adjusted output voltage without constant current regulation and ≥ 85 % of adjusted output voltage with constant current regulation. The signalling threshold of this monitoring automatically follows the adjusted nominal output voltage.

This signal is included in the collective failure signal of the rectifier. Additional there is an optocoupler signal (V_o O.K.)

At operation with internal decoupling diodes the voltage before diodes will be measured.

5.3.3 Output Voltage Low

Output voltage low monitoring; signalling with green LED "Vout>Vmin",

Criterion: output voltage is higher than adjusted level V<;

This signal has its own relay contact on signalling connector. If the voltage value is O.K. Pin 6 and Pin 7 of X2 are closed.

5.3.4 Output Voltage High

Output voltage high monitoring; signalling with red LED "Vout>",

Criterion: output voltage higher than adjusted level V>;

This signal is included in collective failure signal of rectifier. If there is an error the LED is switched ON and the rectifier internally switches OFF. You have to reset the unit by ON/OFF switch.

5.3.5 Protection against Overheating

Protection against overheating; signalling with blinking red LED "Bell symbol", criterion: temperature of heat sink > 90°C. This protection reduces the output power if the temperature is on the limit. This signal is included in collective failure signal. If the temperature is normally the output power will be increased automatically.

5.3.6 Signals

The signals "Vo OK", "Mains OK" and "Constant Current Mode Iconst" are opto coupler signals with a loading of 30 V/5mA. The opto couplers switches off at error. The collective failure signal is delayed for approx. 1sec. The relay contacts between Pin 3 and Pin 5 of X2 are open and between Pin 4 and Pin 5 are closed at error.

5.4 Output and threshold adjustment

The adjustment of output values and monitoring thresholds are very easy. All values will be adjusted with front keys by showing the actual value in the front side digital displays. The activation of the 2nd characteristic via an external circuit is necessary for adjusting the boost charge voltage V_{O2} .

In normal operation the top display shows the output voltage (V_{O1} and V_{O2}) and the bottom display shows the output current (I_o).

For any adjustment please follow the following instructions:

- press both keys UP/DOWN ($\uparrow\downarrow$) together for a short time; the rectifier changes to adjustment mode
- press the key UP (\uparrow) or DOWN (\downarrow) to change the adjustment parameter (see also table on bottom)
- press both keys UP/DOWN ($\uparrow\downarrow$) together for a short time; the rectifier changes to value change mode
- press the key UP (\uparrow) or DOWN (\downarrow) to change the adjustment value (if you hold the key the value changes quicker)
- press both keys UP/DOWN ($\uparrow\downarrow$) together for a short time; the rectifier changes back to the adjustment mode (at this moment the changed value will be stored)
- press both keys UP/DOWN ($\uparrow\downarrow$) for approx. 3 sec. to change back to the operation mode

The adjustment mode is for:

- Adjustment of voltage V_{O1} :
- Normal operation; adjust voltage with potentiometer U_{O1} to correct value (shown at the top display)
- Adjustment of voltage V_{O2} :
- Switch over the unit to V_{O2} -line by external switch (look chapter 6 for correct connecting of signal connector); adjust voltage with potentiometer V_{O2} to correct value (shown at the top display)
- Adjustment of monitoring threshold $V<$:
- Adjust voltage with potentiometer $V<$ to correct value and measure this value on measurement sockets $U<$ in front of the unit
- Adjustment of monitoring threshold $V>$:
- Adjust voltage with potentiometer $V>$ to correct value and measure this value on measurement sockets $V>$ in front of the unit
- Adjustment of the current limit I_{const} :
- The current limit I_{const} is adjusted with the potentiometer I_{const} by external load.

The measure value at the measure bushings $V>$ and $V<$ corresponds to V/cell for 2 cells, i.e. there is a voltage of 4.8V at the measure bushing for adjusting the $V>$ to 2.4 V/cell.

The adjustment ranges and the adjustments in the factory should be picked up from the respective technical data sheet.

Adjustable parameters in adjustment mode:

Display	Parameter
V_{O1} ($=U_{A1}$)	triple charge voltage
V_{O2} ($=U_{A2}$)	boost charge voltage (look also cap. 6.4)
I_o ($=I_A$)	output current
$V<$	output voltage low threshold (look also cap. 5.3.3)
$V>$	output voltage high threshold (look also cap. 5.3.4)
t	coefficient of temperature for temperature compensation of charge voltage (look also cap. 6.2)

The monitoring thresholds automatically follow the adjusted nominal values of output voltage. The monitoring thresholds for mains/step-up-converter and over heating are not changeable.

Details about the adjustment ranges of several threshold values, see section "Technical Data".

6. External Functions

6.1 Output voltage sensor leads

With sense links for output voltage you can compensate voltage losses over wires or diodes. The max. regulation difference is approx. 4% of nominal voltage. Interruption on sense links, confusing of poles or short circuit can not damage the rectifier. At interrupt it can be a voltage increase of max. 4%.

6.2 Temperature Compensation of the charging voltage

At using of closed batteries we recommend the temperature controlled compensation of charge voltage. You have to connect an external active temperature sensor (option) on signalling connector. The coefficient of temperature is normally -4mV/K per cell (at temperature range of 0-50 °C). The basic temperature is 20°C. The coefficient can be adjusted between -1 to -6mV/K per cell. The sensor will be connected with a 2-pole wire (0.25 mm²). It can be mounted directly on top of battery or on battery poles. At big distances (> 2m) we recommend a shielded wire with connection of the shield on rectifiers ground.

6.3 External Switch On/Off

The rectifier can be switched on/off with an external signal. The input is free of potential by an opto coupler and fulfils the supposition for safe electrical decoupling to mains and output side. The signalling voltage is 10-24V, the internal resistance 2.7kOhm. The input is protected against confusing the poles. At higher supply voltages the current in the control circuit has to be limited to 5-7mA using a resistor (for instance 6.8 kOhm at 48/60Vdc).

6.4 Boost Charge Mode

The rectifier module has a second charge line (boost charge line). To select this mode connect a voltage to pin 1 of output connector X3 (see cap. 7.3). The voltage value can be adjusted by the user.

7. Operation Elements and Connectors

7.1 Front View / Operation Elements

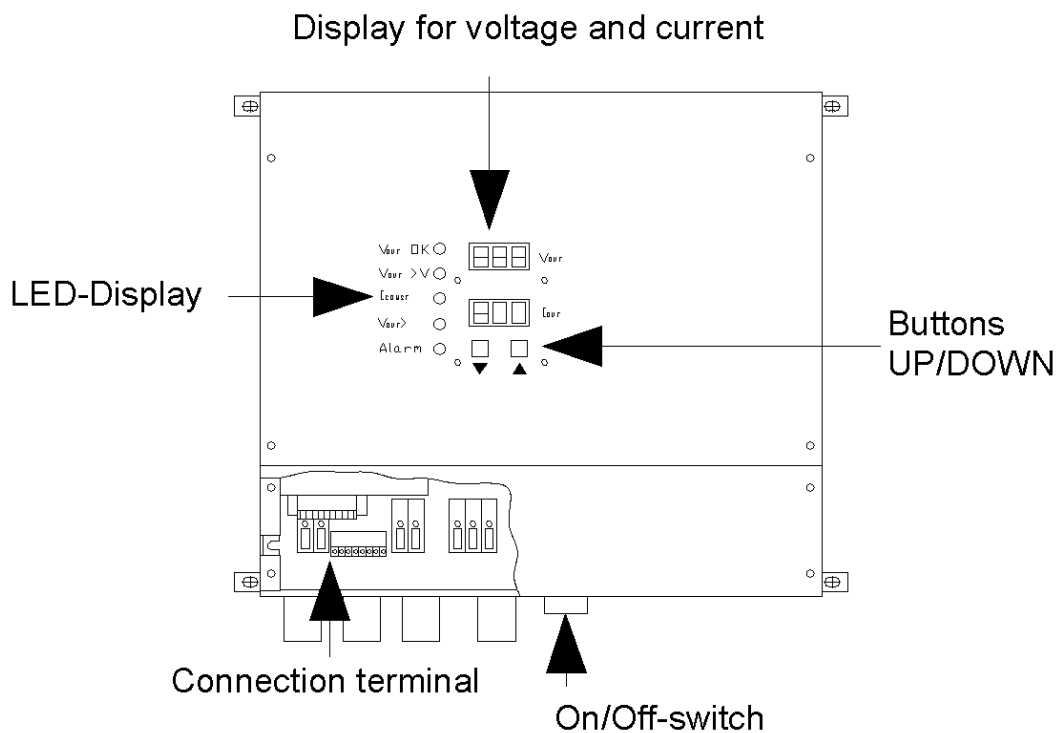

7.2 Indication Instruments

The unit is equipped with LED-instruments 0-999 for current and voltage indication. The accuracy corresponds to Class 1 with reference to the nominal output value of the unit. The indication instrument can be converted to the indication of the adjusted theoretical value for the regulation and monitoring via an external circuit of the signal plug.

Rectifier PSR06-W

User Manual
Page 15 (24)

7.3 Connection Table of Input and Output Terminals

The following picture shows the terminal area (terminal X1, X2, X3) of the rectifier:

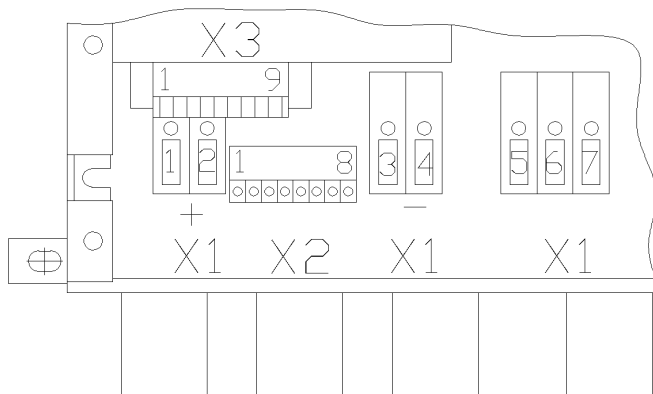

Terminal X1:

X1/Pin	Function
1	DC - Output L+
2	DC - Output L+
3	DC - Output L-
4	DC - Output L-
5	PE
6	N - Input
7	L1 - Input

Terminal X2:

X2/Pin	Function
1	(+) - Sensor lead connection
2	Not connected
3	Signal relay general fault alarm, NO
4	Signal relay general fault alarm, NC
5	Signal relay general fault alarm COM ⁵⁾
6	Signal relay U<,COM ⁵⁾
7	Signal relay U< (total discharge), NO
8	(-) - Sensor lead connection

Terminal X3:

X3/Pin	Function
1	Control input 2. charging-characteristic/Discharge test ¹⁾
2	(+) External On/Off ⁴⁾
3	Optocoupler common emitter
4	Optocoupler C "U ₀ present"
5	+15V DC
6	Optocoupler C "I ₀ "
7	Temperature sensor lead (+) ²⁾
8	Compensating connection for current distribution ³⁾
9	GND

Rectifier PSR06-W

User Manual
Page 16 (24)

Legend:

1)

Pin 1 against +V_o = second V-characteristic

Note:

At 60/108V units there is to be connected an additional resistor in the control wire to +V_o (60V: 18kOhm; 108V: 56kOhm).

2)

Connection of the TK sensor lead 2 >>connect to pin 7 and pin 9

Note:

If a TK-sensor controls several parallel connected modules, then the connection of the pin 7 to the entire parallel circuit is necessary.

3)

At active current sharing mode of paralleled units the pin 8 and 9 of every module has to be connected together.

4)

External On/Off with opto coupler: internal resistor 2,7kOhm, I_{min} < = 5mA, I_{max} = 10mA

Note:

The input is potential free with safe electrical decoupling to primary side and with 500V_{DC} to secondary side.

5)

The relay outputs are potential free with safe electrical decoupling to primary side and with 500V_{DC} to secondary side.

ATTENTION! If you have decoupling diodes in minus at output side the using of sense links are **not** allowed.

8. Maintenance

Due to the implemented components, the SMPS unit virtually is maintenance free. In case of operation in dusty atmosphere, it is regularly advisable to control the dust inside of the unit and, if necessary, blow it out with compressed air. Deposits of dust can result in reduced cooling and could also result in conductive impurities in combination with dew formation or high moisture.

9. Fault finding instructions

Only skilled and trained technical personnel should carry out all necessary operations at the unit.

9.1. Output voltage failure

- Input voltage present?
- Mains switch on?
- Is the input plug correctly inserted?
- Output terminal polarised or short-circuit at the output?
- Parallel operation condition: external decoupling diode polarised?
- Monitoring V_o > responded (LED V_o > lights up)?

>>Corrective action: Switch the unit ON/OFF and examine the adjustment V_o >!

If the unit still does not work even though all checks have been done, contact your sales agent or the ELTEK VALERE INDUSTRIAL service department.

9.2. Output voltage deviation

- Does the unit operate in the current limit due to overload?
Corrective action: Reduce the load!
- Adjustment value of V_o correct?
Corrective action: Readjust the output voltage.
- If external sensors lead connection is used: is the sensor lead connection open?
- Are the decoupling diodes connected in the output circuit?

>>Corrective action: Correct the potential drop by increasing the output voltage of the unit!

If the unit still does not work even though all checks have been done, contact your sales agent or the ELTEK VALERE INDUSTRIAL service department.

10. Technical Data

10.1. General Technical Data

Nominal input voltage range	120-230VAC (-15/+10%)
Frequency	47-63Hz
Nominal input current	2,7A @ 230VAC
Power Factor λ	0.99: 100% > P_{nom} > 50%; 0.97: 50% > P_{nom} > 25%; 0.95: P_{nom} < 25%;
Characteristic curve	IV characteristic according to DIN 41 772/ DIN 41773
RFI	according to EN50081-1
Conduction related	according to EN55011 / EN55022 limit value class "B"
Radiation	according to EN 55011 / EN55022 limit value class "B"
EMC	according to EN50082-2
Cabinet	ESD-test according to EN61000-4 part 2; 6kV contact; 8kV air discharge HF-field according to EN61000-4 part 3; 10V/m (30MHz - 1GHz)
Power cable	Burst-test according to EN61000-4 part 4; 2kV Surge-test according to EN61000-4 part 5; 4kV unsymmetrical; 2kV symmetrical
Control cable	Burst-test according to EN61000-4 part 4; 2kV Surge-test according to EN61000-4 part 5; 2kV unsymmetrical
Function extra low voltage	with safe insulation for $U_0 \leq 60V_{DC}$ according to VDE0100 part 410/11.83, Section. 4.3.2
Dynamic behaviour	$\leq 3\%$ for load steps between 10% - 90% - 10% nominal output current (transient time $t \leq 1$ ms)
Short circuit behaviour	sustained short circuit-proof, 1 x nominal output current
Function monitoring „ V_{01} “ threshold value floating	(green LED "Vout OK") $U_0 \geq 97\%$ of the adjusted output voltage without current limit or $U_A \geq 85\%$ of the adjusted output voltage
Monitoring output under- voltage „ $U_{<}$ “	green LED „Vout > Vmin“, with potential-free contact
Monitoring output over- voltage „ $U_{>}$ “	red LED "Vout >"

Rectifier PSR06-W

User Manual
Page 19 (24)

Constant current operation „I _o “	yellow LED “Iconst”
Over-temperature	red LED “bell symbol”, blinking
Digital instruments: Ammeter:	Indication of 00.1 to 99.9A _{DC}
Voltmeter:	Indication of 00.1 to 999V _{DC}
External functions: Signal “V<”	via potential-free contact (contact charge: 60V _{DC} /1A)
General fault alarm signal	via potential-free relay contact (1sec. time delay); contact charge: 60V _{DC} /1A
Power measuring	for active current sharing
Discharge test/boost charge	voltage value adjustable
Voltage regulation	Temperature compensated
Temperature coefficient	4mV/K per cell with external temperature sensor (optional); temperature adjustable
External sensor lead connection for output voltage “V _o “	Signal via opto coupler V _o present („V _{o1} “ alternatively „V _{o2} “)
constant current operation “I _o “	Signal via opto coupler
External ON/OFF	
Design	Wall cabinet
Protection class	IP 20
Cooling	Convection cooling
Ambient temperature	-20°C to +45°C
Storage temperature	-40°C to + 85°C
Environmental conditions	IEC 721 part 3-3 Class 3K3 / 3Z1 / 3B1 / 3C2 / 3S2 / 3M2
Max. operation altitude	<1500m
Mechanical strength and Shock-proof	according to VDE 0160 issue 5.88 Pt. 7.2.2
Finish	RAL 7035 (front plate)
Weight	approx. 5.3kg
Dimensions	280 x 285 x 95mm (H x W x D)
Connection terminals: AC-Input, DC-Output	Terminal X1
Signalling	Terminal X2/X3
Protective conductor connection	Bolt M4/Terminal X1

Rectifier PSR06-W

User Manual
Page 20 (24)

10.2. Type Specific Data

Type:			
PSR06/ 24-20W	48-10W	60-8.2W	110-4.5W
Article code: 100-006-142.00	100-006-152.00	100-006-162.00	100-006-172.00
Output Voltage V_{O1} (Equalising charge) Adjusted value 27.2V _{DC} ± 1 % Adjustment range 23.4 to 28.8V _{DC}	54,5V _{DC} ± 1 % 46,6 bis 57,6V _{DC}	68.1V _{DC} ±1% 58.5 to 72.0V _{DC}	122.6V _{DC} ±1% 105 to 130V _{DC}
Output voltage V_{O2} (Boost charge) Adjusted value 28.8V _{DC} ± 1 % Adjustment range 24 to 30V _{DC}	57.6V _{DC} ± 1 % 48 to 60V _{DC}	72.0V _{DC} ± 1 % 60 to 73V _{DC}	129.6V _{DC} ±1% 108 to 135V _{DC}
Output current I_O Adjusted value 20A _{DC} ± 2 % Adjustment range 50-100% I _{nominal}	10A _{DC} ± 2 % 50-100% I _{nominal}	8.2A _{DC} ± 2 % 50-100% I _{nominal}	4.5A _{DC} ± 2 % 50-100% I _{nominal}
Type of battery Lead acid battery, 12 cells	24 cells	30 cells	54 cells
Efficiency ≥88 %	≥89 %	≥89 %	≥89 %
Voltage ripple ≤20mV _{pp}	≤20mV _{pp}	≤20mV _{pp}	≤100mV _{pp}
Noise voltage according to CCITT ≤1.2mV	≤1.8mV	≤1.8mV	---
Monitoring:			
DC under voltage V< Threshold value 20.4V _{DC} Adjustment range 19.2 to 24V _{DC}	40.8V _{DC} 38.4 bis 48V _{DC}	51.0V _{DC} 48 bis 60V _{DC}	91.8V _{DC} 86.4 bis 108V _{DC}
DC over voltage V> Threshold value 30V _{DC} Adjustment range 26 to 30V _{DC}	60V _{DC} 52 to 60V _{DC}	75V _{DC} 66 to 75V _{DC}	135V _{DC} 119 to 135V _{DC}

Rectifier PSR06-W

User Manual
Page 21 (24)

11. Dimensional Drawings/Front View

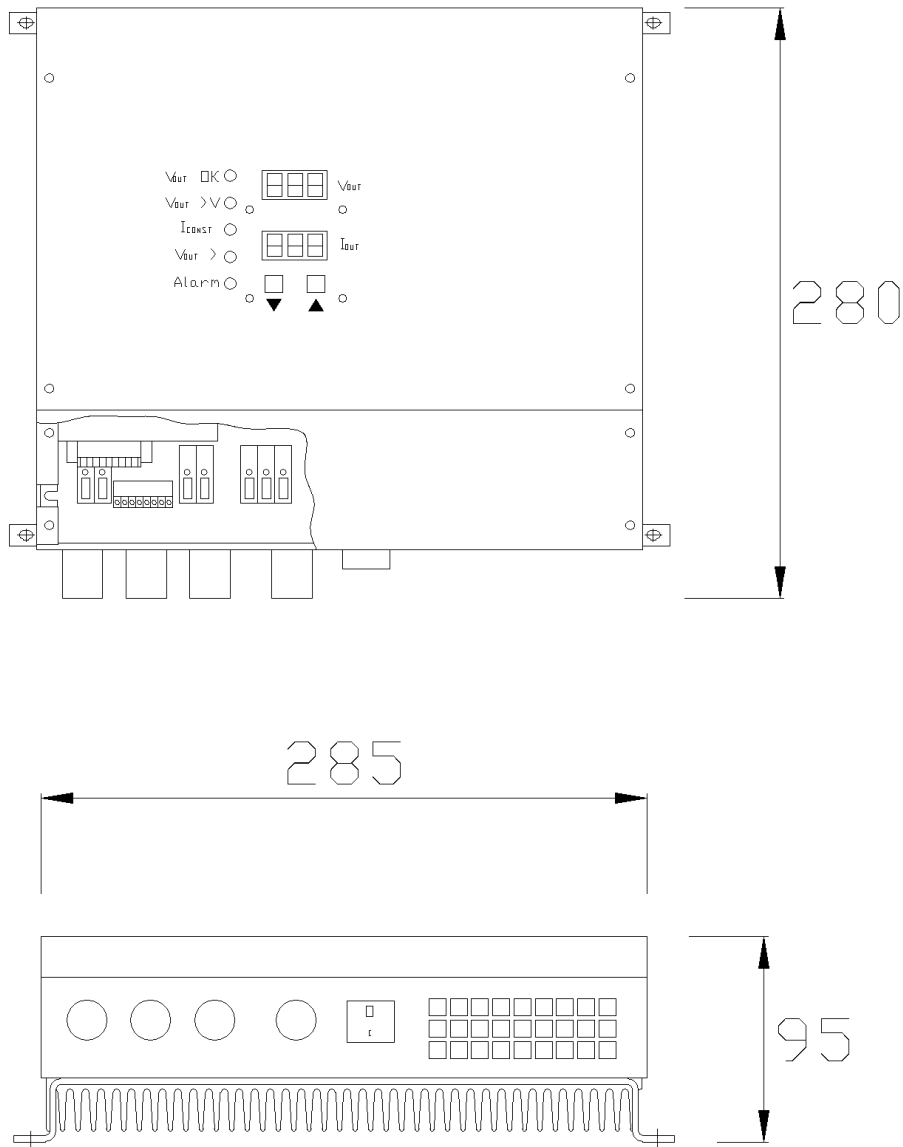



Supplier:

	Eltek Valere Deutschland GmbH Industrial Division Schillerstraße 16 D-32052 Herford
	+ 49 (0) 5221 1708-210
FAX	+ 49 (0) 5221 1708-222
Email	Info.industrial@eltekvalere.com
Internet	http://www.eltekvalere.com